

# ECP250B SERIES

## HIGH VOLTAGE CONTACTORS UP TO 500AMP

### INTRODUCTION

ECP250B series high-voltage DC contactor is designed for control in high voltage environment in battery energy storage system, solar inverter and EV charging applications. It can be used in the 1500VDC voltage system and the enhanced insulation distance can fully meet the requirement in UL60947-4-1 and IEC60947-4-1 standard. The contacts of the ECP250B contactors allow for bi-directional load. Hermetically sealed with ceramic sealing technology makes it safe and reliable.

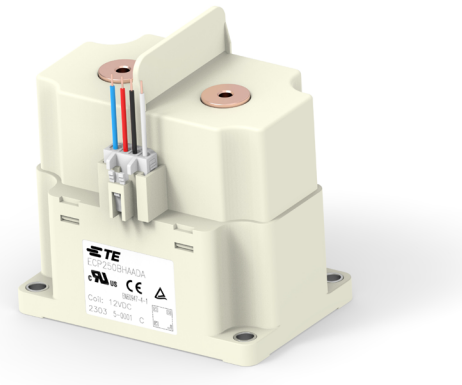

### FEATURES

- Hermetically sealed with ceramic technology
- 500A continuous carry current capability
- Max. breaking capacity 1500VDC at 1000A
- Allow for bi-directional load
- Dual coil design with hold power 5.0W
- Equipped with auxiliary contact
- Comply with DC-1 utilization category in IEC60947-4-1

### APPLICATION

ECP250B contactors can be used for multiple applications including some of the below highlighted

- Battery energy storage systems
- Photovoltaic inverters
- Power conversion system
- Megawatt EV DC charger

### APPROVALS

UL, TUV, CE



**Note:** Technical data of approved types on request

# ECP250B SERIES

## HIGH VOLTAGE CONTACTORS

### MAIN CONTACT DATA

Continuous carry current	500A
Rated Switching Current	250A
Rated Breaking Voltage	1500VDC
Max. Breaking Capacity	1500VDC, 1000A, 1 cycle 1500VDC, 800A, 3 cycles 1000VDC, 2000A, 1 cycle
Contact arrangement	1 Form X (SPST-NO-DM)
Initial Voltage Drop	≤ 0.4mOhm (250A, after 1 minute)
Operate time max. (at 23°C)	50ms
Release time, max. (at 23°C)	30ms
Mechanical Life	200,000 cycles

### CONTACT RATINGS

Load	Cycles
100A, 1500VDC, make/break, resistive	6,000
350A, 1000VDC, break only, resistive	1,000
250A, 1500VDC, break only, resistive	1,000

### CE DECLARATION (IEC60947-4-1)

Rated Operational Current	Rated Operational Voltage	Utilization Category	Switching Cycles
60A	1500VDC	DC-1	6,050

### AUXILIARY CONTACT DATA

Contact Form	1 Form A (SPST-NO)
Contact Current, Max.	2A, 24VDC
Contact Current, Min.	10mA, 24VDC

### COIL VERSIONS, DC COIL

Coil Code	Nominal Voltage	Operate Voltage	Release Voltage	Maximum Operate Voltage	Coil Power
A	12VDC	≤ 9VDC	≥ 1.2VDC	16VDC	Start: 50W Hold: 5W
B	24VDC	≤ 18VDC	≥ 2.4VDC	32VDC	Start: 50W Hold: 5W

All figures are given for coil without pre-energization, at ambient temperature +23°C, and the coil will be automatically switched to 5W hold status after about 200ms energization with coil power 50W.

### INSULATION DATA

Dielectric Withstand Voltage (leakage current <1mA)	
Between open main contacts	4,000 V <sub>rms</sub>
Between main contact and coil	4,000 V <sub>rms</sub>
Between main contacts and aux contacts	4,000 V <sub>rms</sub>
Between open aux contacts	750 V <sub>rms</sub>
Initial Insulation Resistance @ 1500VDC	
Between insulated elements	> 1x10 <sup>9</sup> Ω

### OTHER DATA

Material compliance	EU RoHS/ELV, China RoHS, REACH, Halogen content refer to the Product Compliance Support Center at <a href="http://www.te.com/customer-support/rohssupportcenter">www.te.com/customer-support/rohssupportcenter</a>
Ambient Temperature	-40°C to 85°C
Vibration Resistance (functional)	Sine, 10-2000Hz, 5G
Shock Resistance (functional)	11ms 1/2 Sine, Peak 20G
Terminal Type	Screw for contact, wire for coil
Weight	-1300g
Packaging/unit	box/9 pcs.

**CURRENT CARRY CAPABILITY CURVE**

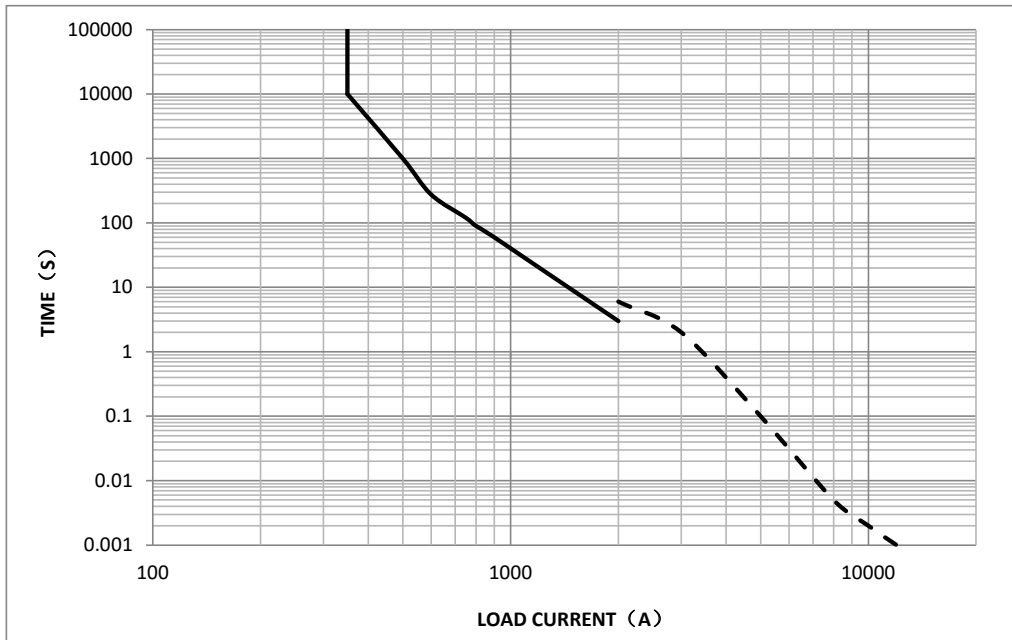

**NOTE**

1. ——— Overload current carry endurance. The data is measured at the environment temperature 85°C with cross section area of wire 120mm<sup>2</sup> min.
2. - - - - Short circuit current endurance. The data is measured at the environment temperature 23°C with cross section area of wire 185mm<sup>2</sup> min. >2000A short circuit current, the judgement criteria of the above reference data is no burning or explosion.
3. Product also meet 500A continuous carry at the environment temperature 85°C with cross section area of wire 2\*150mm<sup>2</sup>. Smaller cross section wires are also allowed depending on the end users conditions.

**ESTIMATED MAKE & BREAK POWER SWITCHING RATINGS**

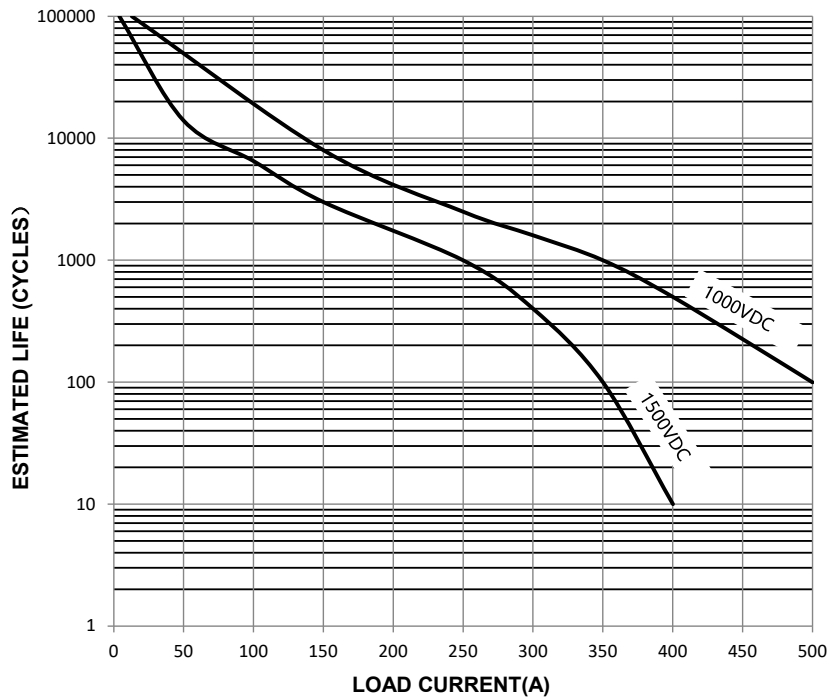

**NOTE**

1. The curve was created based on extrapolated data with few typical points, users are recommended to confirm performance in actual application.
2. The typical data were estimated with resistive load at room temperature.
3. Over 100A @ 1500VDC, only estimated under break only, 1s on/20s off, others were estimated under make and break, 1s on/9s off.

# ECP250B SERIES

## HIGH VOLTAGE CONTACTORS

### DIMENSIONS (Unit: mm)

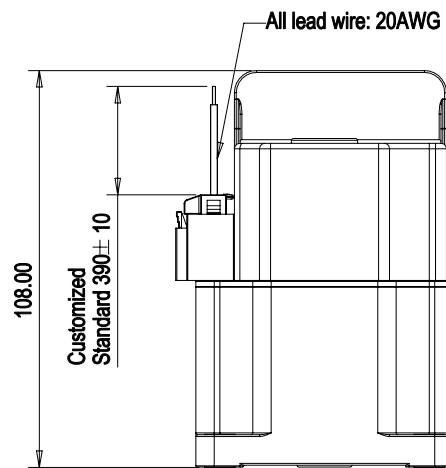
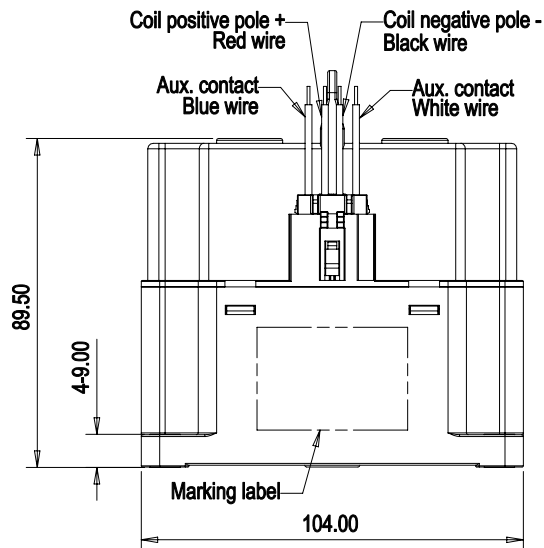
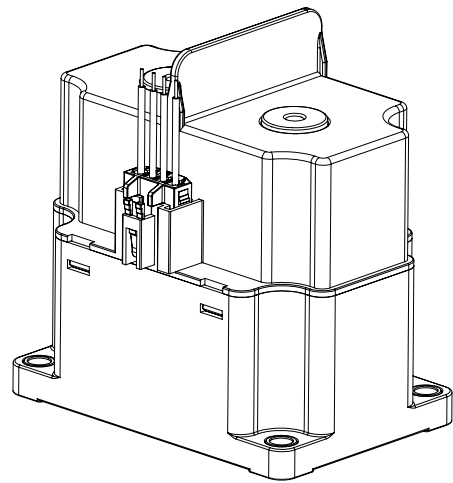
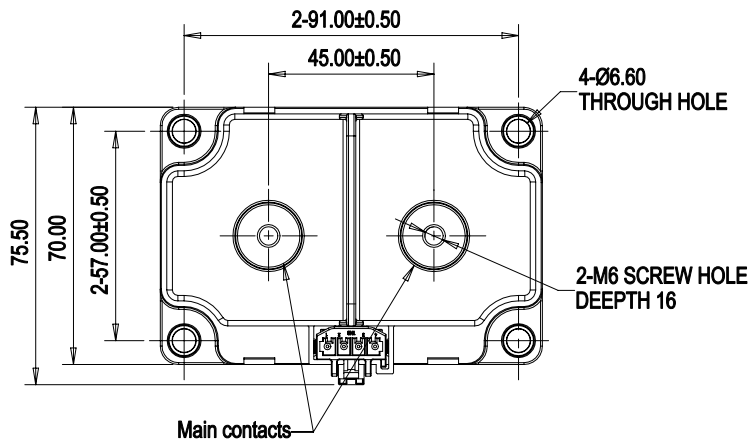

General tolerance	
Dimension	Tolerance
<10	±0.4
10~50	±0.8
>50	±1.2

### CIRCUIT DIAGRAM

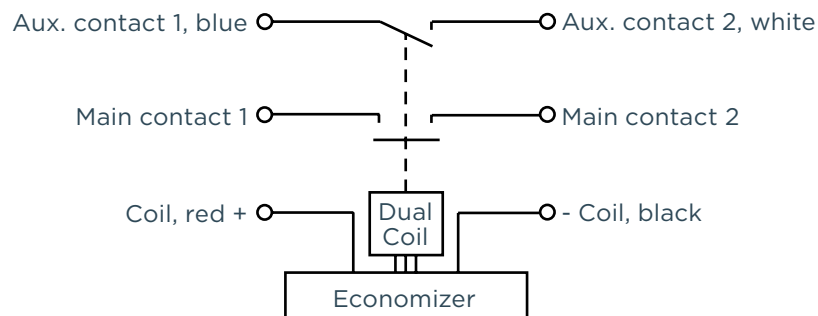

# ECP250B SERIES

## HIGH VOLTAGE CONTACTORS

### PRODUCT INFORMATION

Product code	Contact Form	Mounting Position	Coil	Coil Control Mode	Part Number
ECP250BHAADA	Normally open, with auxiliary contacts (N.O.)	Bottom	12VDC	Dual coil	1-2071568-1
ECP250BHBADA			24VDC		1-2071568-2

### PRODUCT CODE STRUCTURE

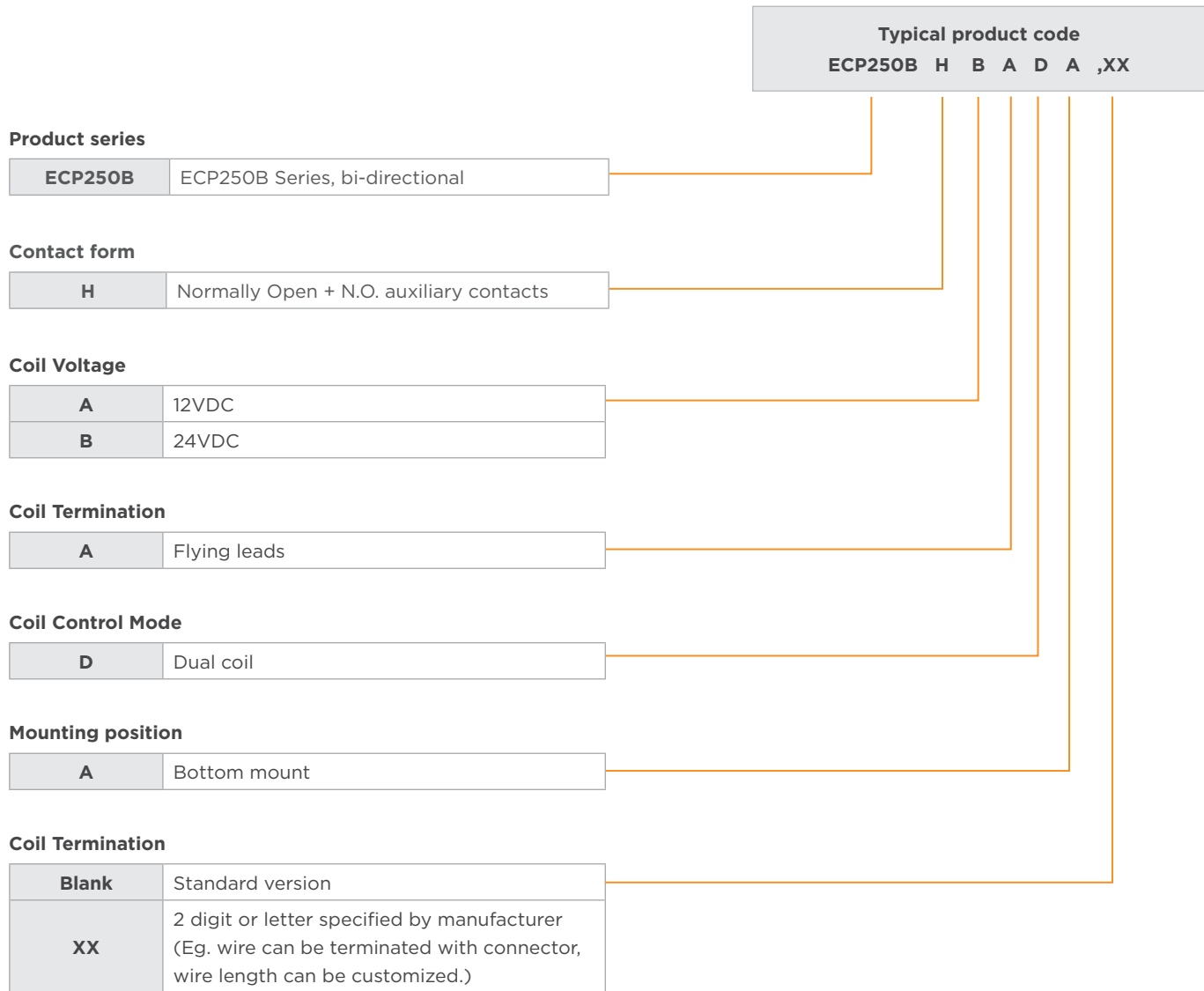

---

## CAUTIONS

1. Do not use the product when product is dropped or broken.
2. Avoid mounting the contactor main contact terminals in downward direction, otherwise the contactor performance will not be guaranteed.
3. There is no polarity difference at the load connection end of this contactor, and no polarity difference at the auxiliary contact connection end. There is a polarity difference at the coil connection end: the red wire is connected to the positive pole of the control power supply, and the black wire is connected to the negative terminal of the control power supply. Please pay attention to the correct installation and use.
4. The nominal value of the contact is the value when the resistive load is applied. In the case of an inductive load (L-load) of  $L/R \geq 1\text{ms}$ , take surge absorption measures in parallel with the inductive load. Otherwise the electrical performance cannot be guaranteed.
5. This product has built-in coil suppression reverse electromotive force circuit, so it does not require surge suppression device. When performing this action voltage test, the voltage cannot rise slowly, Please drive the product coil through the fast rising (step type power supply mode), otherwise the contactors will not operate.
6. The coil type of this product is dual coil, and the coil will be automatically switched to "hold" status after about 0.2 seconds of energization, and the contactor may not operate if energization is less than 0.2s.
7. It is strictly forbidden to place the contactor in an environment that exceeds the temperature range of the product ( $-40^{\circ}\text{C}$ - $+85^{\circ}\text{C}$ ) for a long time.
8. Please avoid installing near strong magnetic boundaries (around transformers and magnets) and heating objects.
9. In order to prevent loosening, please use the gasket correctly when installing the contactor. Screw locking torque of main contact terminals should be 8-10 N·m for M6 screw. Screw locking torque of product bottom mounting should be 3-4 N·m for M5 screw.
10. Please avoid adhering to foreign matter such as grease on the lead end, To maintain the maximum long-term performance, user should select the appropriate connection cable cross section or active cooling to control the temperature.

### Notes:

1. Datasheets and product specification according to IEC 61810-1, EN/IEC60947-4-1, UL60947-4-1 and to be used only together with the 'Definitions' section.
2. Datasheets and product data is subject to the terms of the disclaimer and all chapters of the 'Definitions' section, available at <http://relays.te.com/definitions>.
3. Datasheets, product data, 'Definitions' section, application notes and all specifications are subject to change.

## te.com

©2023 TE Connectivity. All Rights Reserved.

TE Connectivity, TE connectivity (logo) and Every Connection Counts are trademarks. All other logos, products and/or company names referred to herein might be trademarks of their respective owners.

The information given herein, including drawings, illustrations and schematics which are intended for illustration purposes only, is believed to be reliable. However, TE Connectivity makes no warranties as to its accuracy or completeness and disclaims any liability in connection with its use. TE Connectivity's obligations shall only be as set forth in TE Connectivity's Standard Terms and Conditions of Sale for this product and in no case will TE Connectivity be liable for any incidental, indirect or consequential damages arising out of the sale, resale, use or misuse of the product. Users of TE Connectivity products should make their own evaluation to determine the suitability of each such product for the specific application.

03/23 ED